 **KINGS ELECTRONICS CO., INC. TUCKAHOE, NEW YORK**

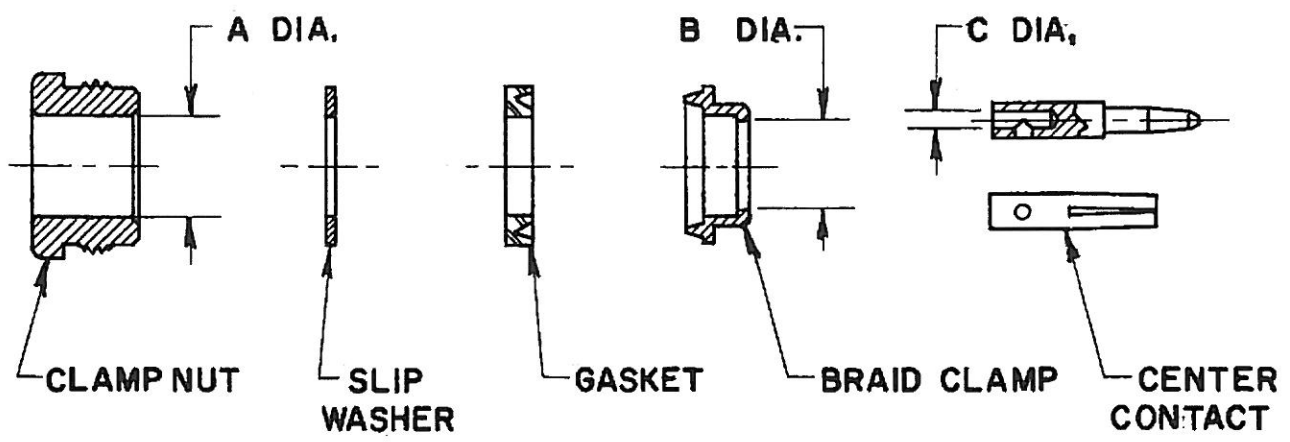

MILITARY PART NUMBER	KINGS NUMBER	CABLE USAGE	PIECE PART DIM'S.		
			A DIA.	B DIA.	C DIA.
M39012/06-0001 M39012/08-0002 M39012/11-0001	KD-59-132 KD-19-71 KD-19-61	RG-5,6,21,143, 212,222,304/U	.35	.27	.06
M39012/06-0002 M39012/08-0001 M39012/11-0002	KD-59-119 KD-19-72 KD-19-73	RG-8,9,213, 214/U	.44	.37	.10

NOTES: 1. INSTRUCTION SHEET TO BE WHITE SULPHUR FREE PAPER.
 2. PRINT SHEETS 1 AND 2 ON BOTH SIDES OF SHEET.

REDUCE TO 2 1/2 IN. X 3 IN.

REVISIONS		REVISIONS		DATE
ISSUE	CHANGES	ISSUE	CHANGES	
2	CN 28236 B MJB 13 AUG 86			13 AUG 86

KINGS
ELECTRONICS CO., INC.
TUCKAHOE, NEW YORK 10707



KINGS ELECTRONICS CO., INC. TUCKAHOE, NEW YORK

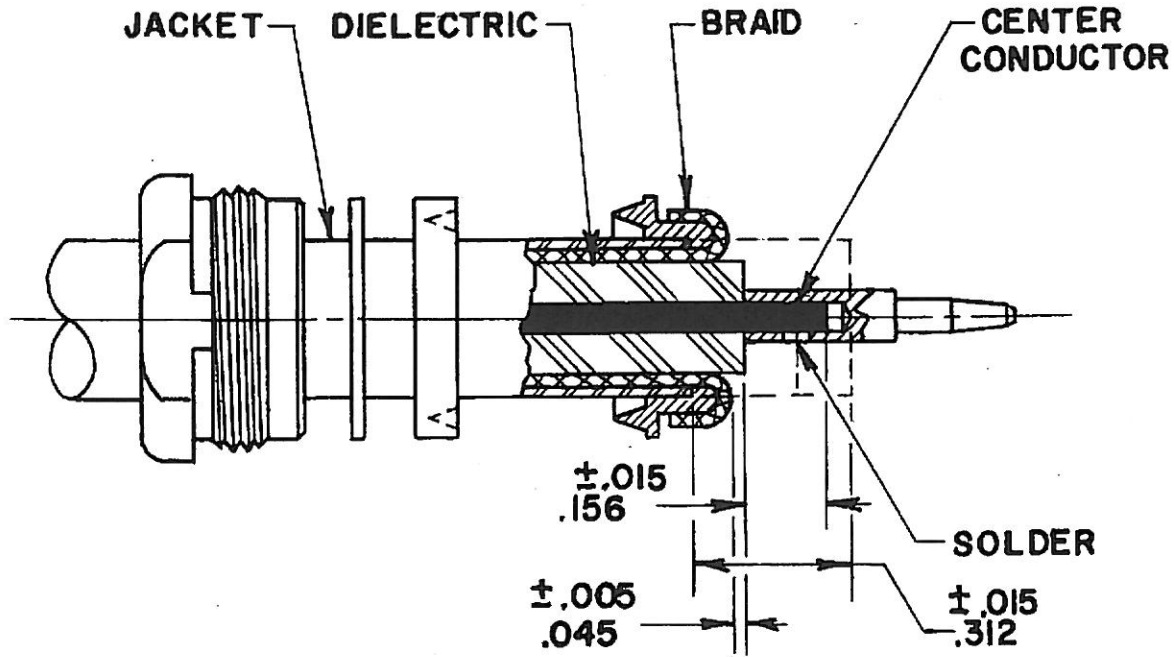

1. WITH CLAMP NUT, SLIP WASHER & GASKET ON CABLE, REMOVE JACKET TO $.312 \pm .015$ DIM.
2. SLIDE BRAID CLAMP OVER BRAID AGAINST JACKET EDGE. COMB OUT BRAID WIRES, FOLD BACK OVER BRAID CLAMP & TRIM AS SHOWN.
3. REMOVE DIELECTRIC TO $.045 \pm .005$ DIM. & TRIM CENTER CONDUCTOR TO $.156 \pm .015$ DIM.
4. SOLDER CENTER CONTACT TO CENTER CONDUCTOR.
5. THREAD ASSEMBLY SECURELY INTO CONNECTOR BODY.
RECOMMENDED TORQUE: 55-60 IN.LBS.

573C-1

(OVER)

REDUCE TO 2 1/2 IN. X 3 IN.

REVISIONS

ISSUE CHANGES

2 CN 28236B
MJB 13 AUG 86

REVISIONS

ISSUE CHANGES

DRAWN CHC
APPR. MJB

DATE 13 AUG 86

KINGS
ELECTRONICS CO., INC.
TUCKAHOE, NEW YORK 10707

573C-1 (SHEET 2 OF 2)